



**PTI40 Series
Premier Accuracy Intelligent
Pressure Transmitters**



WARNING

Read this manual before working with the product. For personal and system safety and for optimum product performance, make sure you thoroughly understand the contents before installing, using, or maintaining the NOSHOK PTI40 Series Transmitters. Read the precautions and warnings on the last page.

Table Of Contents

SECTION		PAGE
1	Introduction	6
1.1	Description Series PTI40	6
1.2	Drain And Vent Valves	6
2	Dimensional Drawings	7
2.1	Applications	7
3	Installing The Transmitter	8
3.1	Transmitter Housing (Fully Rotatable)	8
3.2	Manifolds (Optional)	8
3.3	Mounting Position	8
3.4	Mounting Position Effect	8
3.5	Process Connection	9
3.6	Calibration	9
3.7	Wiring	9
3.8	Grounding	9
4	Remaining	10
4.1	External Load	10
4.2	CE/EMC Rules	10
5	Graphic Display And Navigation Button	11
5.1	Graphic Display Readout	12
5.2	Summary Programming Points	13
6	Explanation Programming Points P101 to P116	14
	P101 Zero Adjustment (4 mA)	14
	P102 Span Adjustment (20 mA)	15
	P103 Cancel Mounting Position Effect (4 mA)	16
	P104 Display Setting Of Units	16
	P105 Output Selection 4-20 mA Or 20-4 mA	17
	P106 Damping Adjustment	17

Table Of Contents

SECTION		PAGE
	P107 Language	18
	P108 Device Setup	18
	P109 Readout	19
	P110 Current Simulation (4-20 mA)	20
	P111 Tank Linearization	21
	P112 Burst Mode	33
	P113 Information	34
	P114 Square Root	35
	P115 & P116 Factory	38
7	Programming The PTI40 Series	38
7.1	Programming With Hand Held Terminal	38
7.2	Rotatable Display	39
8	Specifications	40
9	Precautions And Warnings	41

1 INTRODUCTION

The Series PTI40 is a high-end pressure, differential pressure and flow transmitter based upon a piezoresistive silicon sensor, with a very high burst pressure. The sensor element is mounted in a stainless steel body. Pressure on the sensor element creates a very small deflection of the silicon substrate and bridge network. The resulting strain in the silicon resistors causes a change in the bridge resistance that is proportional to the pressure/differential pressure applied. The transmitter electronics detects this change in bridge resistance and converts it into 4-20 mA. The amplifier system is based on a single microprocessor, which ensures a perfect linearity in the 4-20 mA output, all within an accuracy of 0.075%.

1.1 DESCRIPTION SERIES PTI40

The Series PTI40 is specially designed as a differential pressure transmitter. The wetted parts are standard made of 316L SS, other diaphragm materials are available, like Hastelloy C and Tantalum. The process connections are standard fitted with 1/4" NPT female thread. All process connections meet the requirements of IEC 61518.

All transmitters are fully temperature compensated, which means that various process temperatures have nearly no effect on the accuracy of the output signal.

1.2 DRAIN AND VENT VALVES

As standard the PTI40 is supplied with two drain/vent valves. They can be screwed from the PTI40 body to drain or vent the process. These valves must be kept clean.

2 DIMENSIONAL DRAWINGS

PTI40

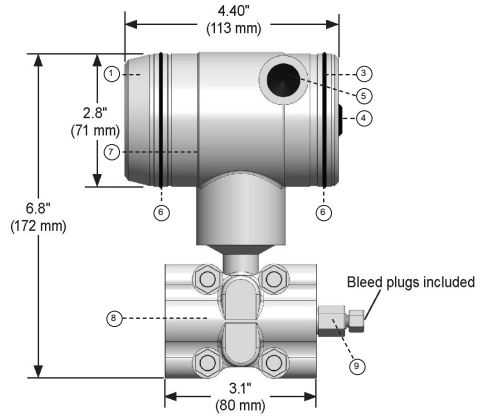
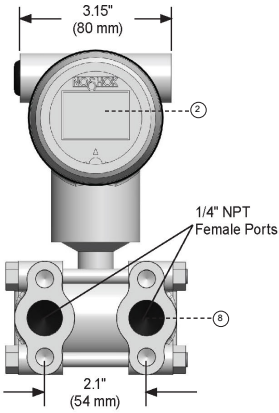

Front view: Transparent cover

Description	Material	Description	Material
① Cover	304 SS	⑥ O-Ring	EPDM
② Display with navigation button		⑦ Electronic housing	304 SS
③ Cover	304 SS	⑧ Body with process connection: 1/4–18 NPT f	316 SS
④ Venting	PA	⑨ Vent valve	316 SS
⑤ 1/2 NPT female			

2.1 APPLICATIONS

The Series PTI40 can be used in wide variety of applications such as differential pressure, level and flow measurement.

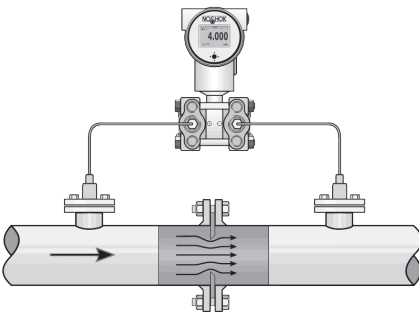

$\sqrt{\text{SQUARE ROOT}}$

Flow measurement, for example:
Orifice flanges, Pitot tubes and Venturi tubes

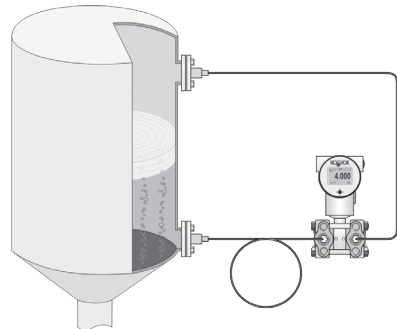



Differential pressure measurement with flanged connection.

3 INSTALLING THE TRANSMITTER

The Flange of the transmitter is protected with a special protection cap. It is advisable to only remove this protection until installation. Do not damage the diaphragm or any part of the process connection. **Do not dismantle the process connection (Sensor body).**

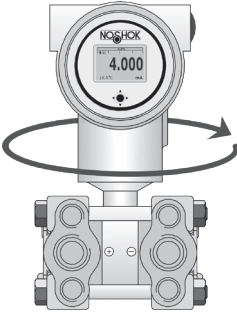
3.1 TRANSMITTER HOUSING (FULLY ROTATABLE)



The transmitter housing can be fully rotated both ways 360° degrees. Untighten the hexagon screw  on the outside of the enclosure. Rotate the transmitter housing to the desired position and fix the position by tightening the hexagon screw on the outside of the enclosure. The construction prevents the housing from being rotated too far. Where necessary the display can also be rotated separately from the transmitter housing to the desired position for most optimum readout.

3.2 MANIFOLDS (OPTIONAL)

The PTI40 can be supplied with a 3 or a 5-way manifold. The manifold separates the transmitter from the actual process. The advantage of a manifold is simple installation and easy maintenance without interrupting the process. This means higher system availability and even simpler commissioning or maintenance purposes. If a manifold is applied, the process connection will change from 1/4" NPT (f) to 1/2" NPT (f) thread.



3.3 MOUNTING POSITION

When the transmitter is mounted horizontally, the cable gland should be pointed downwards.

3.4 MOUNTING POSITION EFFECT

All transmitters are calibrated in vertical position. If the transmitter is mounted in another position, there can be a little zero shift. (For example 4.020 mA instead of 4.000 mA).



After installation of the transmitter the zero must **ALWAYS** be set to 4.000 mA with P103 Cancel mounting position effect. This will not affect the span.

3.5 PROCESS CONNECTION

Before mounting of the transmitter, be aware of the correct position of the high and low pressure side. The process connection is clearly marked with the symbols + and -.

3.6 CALIBRATION

All transmitters are fully calibrated at the factory, to customer specified range. If the calibration is not specified, the transmitter will be calibrated at the maximum span.

3.7 WIRING

Under the cover ③ you will find the terminal board.

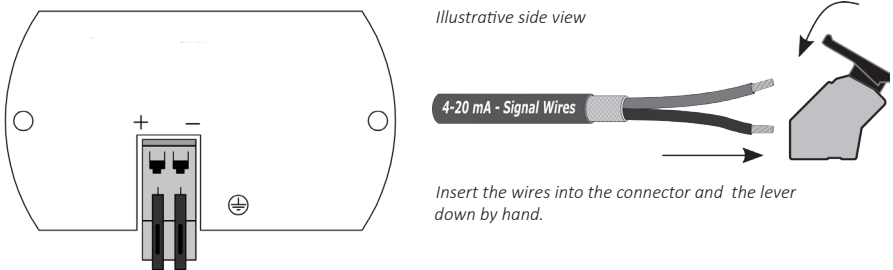

The figure above shows the wiring connection of the transmitter. The 2-wires must be connected to + and - on the terminal board. The wiring terminals can be operated without a screwdriver. The opening levers of the terminals can be lifted and pressed down by hand. Lift the opening levers of the terminals and insert the corresponding wires. Press down the levers by hand, the terminal spring will close and the wire is clamped.

The transmitter must be connected with standard two-wire shielded cable. Do not run signal wiring in open trays with power wiring, or near heavy electrical equipment (for example: Frequency controllers or heavy pumps).

Reversing the polarity will not damage the transmitter, but the transmitter will not function until the wires are properly connected.

3.8 GROUNDING

The transmitter must always be connected to ground. In case the process connection is already connected to ground (for example: by tank or pipe line) do not connect the instrument to ground. Please ensure that the instrument is not connected to ground twice to prevent a ground loop.

4 REMAINING

4.1 EXTERNAL LOAD

External loads must be placed in the negative side of the 2-wire loop. The minimum power supply is based on the total circuit resistance. The maximum external load (RI max.) for 24 Vdc will be 600 Ω (Ohm). At a higher power supply, the external load can be up to max. 1200 Ω / 36 Vdc.



With a loop resistance of 250 Ω a power supply of at least 17 Vdc must be used.

$$RI \text{ max.} = \frac{\text{Voltage} - 12 \text{ V (min. voltage)}}{20 \text{ mA}}$$

4.2 CE / EMC-RULES

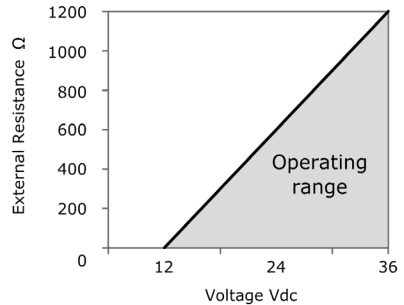
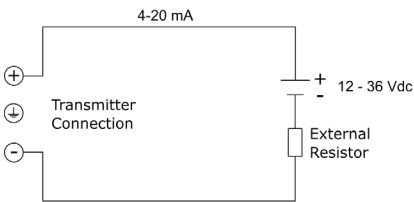

All NOSHOK transmitters are manufactured in accordance with the RFI / EMC directives and comply with the CE standard. All transmitters are fitted with RFI filters, which provide optimum, trouble-free operation. Our products are in conformity with EMC-Directive 2004/108/EC based on test results using harmonized standards.

5 GRAPHIC DISPLAY AND NAVIGATION BUTTON

The PTI40 Series has a multifunctional display where different values can be displayed simultaneously. The display is equipped with a backlight. The entire menu is controlled by a navigation button. The navigation button has the following possibilities of movement: up, down, left, and right. The navigation button needs to be pressed when conformation or saving is needed.

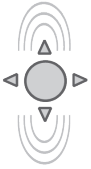

Move the navigation button up or down to browse through various menus. These movements can be distinct in choices of: program points, navigation through menu's and increase or decrease measurement value's.

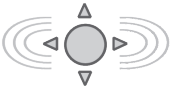

Move the navigation button left or right to navigate horizontally through the menu or positions on the display.



It is always possible to return to the previous menu. Move the navigation button to the left to return to the previous menu.



By pressing the navigation button each choice will be confirmed or a setting will be saved.

Display PTI40 Series, fully rotatable (360°)

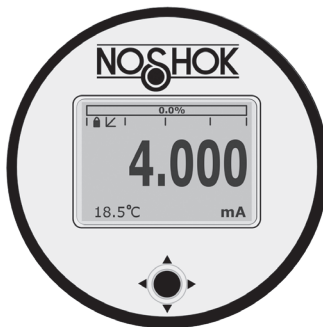

5.1 GRAPHIC DISPLAY READOUT

When the transmitter is powered, a flash screen with the name of the transmitter (PTI40 Series) and the software version appears for a few seconds. After this, the home screen will show the measured value as set in the factory.

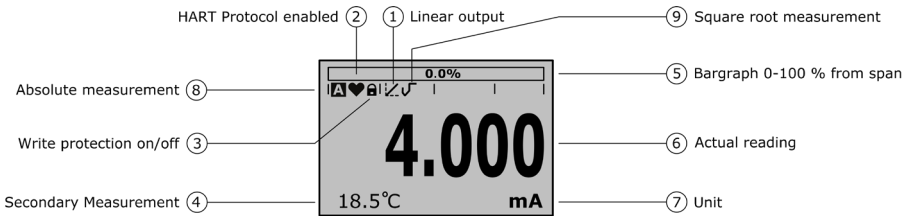

EXPLANATION OF SYMBOLS:

- 1. Linear output:** Displays when any form of linearization is applied. A straight line means no linearization is applied. When a linearization is applied a curve will be displayed.
- 2. HART® Protocol:** Displays a HART® symbol.
- 3. Write protection on/off:** Displays if protection against adjustments and configuration is on or off
- 4. Secondary Value:** Displays a secondary chosen measurement.
- 5. Bargraph 0-100 % from span:** Displays the percentage of the measured span.
- 6. Actual reading:** Displays the current measurement in mA, percentage or a selectable unit.
- 7. Unit:** Displays the selected unit.
- 8. Absolute Sensor:** Displays when the measurement is in absolute range.
- 9. Square root:** Displays when a flow measurement is enabled.

5.2 SUMMARY PROGRAMMING POINTS

Programming points	
P100	Start and exit
P101	Zero adjustment (ZERO 4 mA) with or without test pressure
P102	Span adjustment (SPAN 20 mA) with or without test pressure
P103	Cancel mounting position effect (4 mA)
P104	Selection of engineering unit to be displayed
P105	Output selection 4-20 mA or 20-4 mA
P106	Adjustable damping (0.00 till 25.00 s)
P107	Language choice between: English, Dutch, German, Russian, Polish and French.
P108	Configuration of: Protection, Alarm, Backlight, Temperature, Secondary value, Set time and HART® Version.
P109	Readout options on display: Current, unit, percentage and temperature
P110	Current simulation 4-20 mA (Stepwise or free adjustable)
P111	Configuration for tank linearization
P112	Configuration for burst mode
P113	Contact information of NOSHOK, settings, and software revision
P114	Flow configuration: Linear and ($\sqrt{\quad}$) Square Root
P115	Only available for the manufacturer
P116	Only available for the manufacturer

6 EXPLANATION PROGRAMMING POINTS P101 to P116

P101

ZERO ADJUSTMENT (4 mA)

The transmitter is set to 0 psi at atmospheric pressure. The ZERO can be adjusted at a lower or higher point. This will be explained step by step by an example.

Example: Increase ZERO to 1.45 psi.

1. The measuring unit of the transmitter is set to psi. If not this can be selected by choosing the right measuring unit in program point **P104 - UNITS**
2. Navigate to program point **P101 - ZERO Value**, and press the navigation button to enter the menu.
3. Two choices appear on the screen: **Set manual** and **Use process**
Set manual = Configuration without test pressure.
Use process = Configuration with applied pressure.
4. Choose **Set manual**, +000.0 (psi) will appear on the display.
5. Increase the value with the button to 1.45 psi, press to confirm, and select **SAVE** to save the setting. The transmitter will return to the home screen. The measurement value at atmospheric pressure is now 1.45 psi. With an applied pressure of 1.45 psi, the transmitter will display 4 mA

The menu zero adjustment also has the choice of **Use process**. The transmitter can be adjusted to zero in a real process situation. When chosen, the transmitter will measure the pressure in an actual process. This measurement will be used as the zero value. (4 mA)

1. Navigate to program point **P101**, and press the button to enter the menu.
2. Choose **Use process**, and press to confirm. The transmitter will display the actual measured value.
3. Press the navigation button to confirm, and select **SAVE** to save the setting.
4. The transmitter will return to the main menu.

The **ZERO** will automatically be set to 0.000 when enabling the Square Root function. After enabling the Square Root function, the ZERO (Program point P101) cannot be configured.

SPAN ADJUSTMENT (20 mA)

This setting can be used to adjust the range (SPAN) according to an entered value or adjusted with or without an applied pressure.

The maximum pressure which can be measured (20 mA) is the measurement at ZERO (P101) + the entered value SPAN (P102). If the ZERO (P101) is increased, then the maximum measured value will automatically be set higher at the same rate as the zero. This will be explained step by step by an example.

Example: Measurement range 0 – 29 psi = 4 - 20 mA.
The **span** must be set at 29 psi.

1. Navigate to program point **P102 - SPAN Value**, and press the navigation button to enter the menu.
2. Two choices appear on the screen: **Set manual** and **Use process**. Choose **Set manual**, a value will appear on the screen. (Depending on the range.)
3. Adjust the **SPAN** with the navigation button to 29 psi and select **SAVE** to save the setting.
4. The transmitter will return to the home screen.

The menu span adjustment also has the choice of **Use process**. The transmitter can be adjusted to the span in a real process situation. When chosen, the transmitter will measure the pressure in an actual process. This measurement will be used as the span value. (20 mA)

1. Navigate to program point **P102**, and press the button to enter the menu.
2. Choose **Use process**, and press to confirm. The transmitter will display the actual measured value.
3. Press the navigation button to confirm, and select **SAVE** to save the setting.
4. The transmitter will return to the main menu.

P102 is the adjustment of the total span.

When a compound range must be adjusted (for example -14.5 to +43.5 psi), a span of 29 psi must be programmed.

The Zero (P101) must be set at -14.5 psi. The transmitter is adjusted at -14.5 psi = Zero and +43.5 psi = Span.

I

P103**CANCEL MOUNTING POSITION EFFECT (4 mA)**

All transmitters are vertically calibrated. If the transmitter is installed horizontally, the transmitter has a small mounting position effect on the zero (4 mA). The current value will be for example, 4.020 mA instead of 4.000 mA. This effect can be neutralized in this menu.

1. Navigate to program point **P103 – MOUNT corr.**, and press the navigation button to enter the menu.
2. Two choices appear on the screen: **Set** and **Reset**. Choosing **Set** will adjust the zero to 4.000 mA in the mounting position when applicable.

- Select **Set** and press the button to confirm.
- The **Save** icon will be displayed to indicate that the setting is saved.
- The transmitter will return to the main menu.

Choosing **Reset** will put the transmitter back to factory setting. (vertical adjustment 4 mA)

- Select **Reset** and press the button to confirm, the setting will be put back to factory setting. The **Save** icon will be displayed to indicate that the setting is saved.
- The transmitter will return to the main menu.



Do not apply pressure while executing Cancel mounting position effect for low pressure ranges, the mounting effect on the zero point will be more noticeable, therefore it is important to execute P103 before installing the transmitter.

P104**DISPLAY SETTING OF UNITS**

Various engineering units can be displayed on the display. Factory setting = psi

1. Navigate to program point **P104 – UNIT**, and press the navigation button to enter the menu.
2. Several engineering units can be selected. Each selected engineering unit is automatically converted to the correct value of the corresponding unit.
3. Navigate through this menu and choose the required unit, press to confirm.
4. The **Save** icon will be displayed to indicate that the setting is saved.
5. The transmitter will return to the main menu. The measured reading will be displayed in the chosen unit in the home screen.



The selected pressure unit is only visible on the display, when UNITS is chosen in program point P109 – Readout.

P105**OUTPUT SELECTION 4-20 mA or 20-4 mA**

The transmitter is standard set to 4-20 mA.

1. Navigate to program point **P105 – Reverse mA**, and press the navigation button to enter the menu.
2. Two choices appear on the screen:
4-20 mA and **20-4 mA**
3. Make an output choice and press to confirm.
4. The **Save** icon will be displayed to indicate that the setting is saved.
5. The transmitter will return to the main menu.

P106**DAMPING ADJUSTMENT**

The transmitter has an adjustable damping between 0.00 to 25.00 seconds.

Factory setting = 0.00 seconds

1. Navigate to program point **P106 – DAMPING**, and press the navigation button to enter the menu.
2. Two choices appear on the screen: **Set** and **Reset**
3. Make a choice and press to confirm.

Choosing **Set** allows a value to be set between 0.00 and 25.00 seconds.

- Select **Set**, and press the button to confirm.
- Adjust the damping with the navigation button, press to confirm.
- The **Save** icon will be displayed to indicate that the setting is saved.
- The transmitter will return to the main menu.

Choosing **Reset** will put the setting back to factory setting (0.00 seconds)

- Select **Reset**, and press the button to confirm.
- The **Save** icon will be displayed to indicate that the setting is saved, the setting will be put back to factory setting: 0.00 seconds.
- The transmitter will return to the main menu.

P107**LANGUAGE**

In this menu the preferred menu language can be selected.

1. Navigate to program point **P107 - Language**, and press the navigation button to enter the menu.
2. The choices appear on the screen: **English, Dutch, Spanish, German, Russian, Polish** and **French**.
3. Make a choice and press to confirm.
4. The **Save** icon will be displayed to indicate that the setting is saved.
5. The transmitter will return to the main menu.

P108**DEVICE SETUP**

In this menu, several operational settings can be made for the transmitter and the display.

1. Navigate to program point **P108 – Device Setup**, and press the navigation button to enter the menu.
2. Nine choices appear on the screen:
Protection, Alarm output, Backlight, Temp units, Temp min/max, Sec. Value, Set Time, HART® Version and Polling Address.
3. Choose the desired option, press to confirm.
4. Below are the choices displayed. They can be selected and configured using the navigation button.
 - **Protection:**
 - **Local:** The local protection for adjusting settings locally on the transmitter.
 - **External:** The external security for adjusting settings remotely on the transmitter by HART® protocol.
 - **Alarm output:**
 - **Low:** The lower limit of the lowest permissible current value. (3.2 mA)
 - **High:** The upper limit of the maximum permissible current value (22.8 mA)
When exceeding the above limits, a warning symbol will display on the screen.
 - **Backlight:** Choice between: **On, Sleep mode** (Turn off backlight after 5 minutes) and **Off**. The intensity of the backlight is depending on the output current.
 - **Temp units:** Choice between: Celsius and Fahrenheit.
 - **Temp min/max:** Two choices appear on the screen: **Readout** and **Reset**.

By choosing **Readout** the last measured minimum and maximum temperature values of process and ambient appear. For the process temperature, a new value is stored in a change of temperature more than 2 °F. For the ambient temperature this is 5 °F.

By choosing **Reset** the previous stored values will be deleted.

- **Sec. Value:** Four choices appear on the screen for the secondary readout on the main screen: **Current, Unit, Rate and Temperature.**
- **Set Time:** (Only with HART® 7) An input screen to enter the date and time will appear.
- **HART® version:** Choice between: **HART® 5.0** and **HART® 7.0.**
- **Polling Address:** A Polling Address from 0 ... 63 can be configured (Standard Address is 0)

P109

READOUT

In this menu, the readout on the display is determined. This is the type of measurement that appears on the home screen. Factory Setting = Unit

1. Navigate to program point **P109 – READOUT**, and press the navigation button to enter the menu.
2. Nine choices appear on the screen:
 - Current** = Present current value (4-20mA)
 - Unit** = Pressure unit as chosen in P104
 - Percentage** = 0 - 100 %
 - Temperature** = Actual sensor temperature (°F or °C)*
 - Hectoliter** = Number of hectoliters (only possible in combination with linearization P111)
 - Cubic meter** = Number of cubic meters (only possible in combination with linearization P111)
 - Liter** = Number of liters (only possible in combination with linearization P111)
 - Kg** = Number of kilograms (only possible in combination with linearization P111) After selecting this readout the **Specific Gravity** of the medium (**SG** = g/cm³) must be entered with a value between 0.2 and 4.0 g/cm³. The specific gravity will appear on the home screen (g/cm³) under the primary chosen readout. This readout will be indicated as a linear measurement, and displayed by the symbol  on the home screen.

Tonne = Number of tons (only possible in combination with linearization P111)

After selecting this readout, the **Specific Gravity** of the medium (**SG** = g/cm³) must be entered with a value between 0.2 and 4.0 g/cm³. This readout will be indicated as a linear measurement, and displayed by the symbol  on the home screen. The specific gravity will appear on the home screen (g/cm³) under the primary chosen readout.

3. Navigate to the desired choice, confirm the selection by pressing the navigation button.
The **Save** icon will be displayed to indicate that the setting is saved.
4. The transmitter will return to the main menu.

*(Indication of process temperature, accuracy depending on sensor position)



For measuring weight (Kg and Tons), a reliable accuracy cannot be guaranteed, the PTI40 Series pressure transmitter cannot compensate for Specific Gravity changes or any thermal increase or decrease.

P110

CURRENT SIMULATION (4-20 mA)

The transmitter can simulate an output between 4-20 mA. Using five predefined steps or a free selectable value between 3.80 mA to 20.8 mA (Transmitters with HART® Protocol 3.90 mA to 20.8 mA)

1. Navigate to program point **P110** – CURR SIMU, and press the navigation button to enter the menu.
2. Two choices appear on the screen: **Set** and **Free**
3. Choosing **Set** allows a value to be set in five steps: 4, 8, 12, 16, 20 mA
 - By default, the current simulation is **Not active**, as shown in the display
 - Choose one of the five steps, and press to confirm
 - The status on the display changes to **Active** and the current simulation is started for the selected step.
 - Press the navigation button to de-activate the current simulation.
 - Move the navigation button to the left to go back and leave this menu.
4. With the option **Free**, a current between 4 and 20 mA can be configured.
 - By default, the current simulation is **Not active**, as shown in the display.
 - Enter the desired value, and press to confirm.

- The status on the display changes to **Active** and the current simulation is started for the selected value.
- Press the navigation button to de-activate the current simulation.
- Move the navigation button to the left to go back and leave this menu.

P111

TANK LINEARIZATION

In this menu, various tank linearization's can be selected.
Factory setting = No linearization

For a horizontal tank or a tank with a cone, linearization can be configured. The volume as a measured value will be displayed on the home screen. (Must be set in **P104**)
 The values (configured in the following settings) **must be in meters.**

Navigate to program point **P111 – TANK LIN**, and press the navigation button to enter the menu.
 Six choices appear on the screen:

- **No Lin** = No linearization
- **Hor. Tank** = Linearization setting for a horizontal tank: cylindrical and elliptic
- **Vert. Cone** = Linearization setting for a vertical tank with a conical bottom.
- **Vert. Sphere** = Linearization setting for a vertical tank with a spherical bottom.
- **Vert. Trunc** = Linearization setting for a vertical tank with a truncated bottom.
- **Free Lin** = Free linearization setting, adjustable in 70 free programmable points.

The following describes the setting for each linearization configuration.

LINEARIZATION DISABLE

With the choice **No. Lin.** an existing linearization can be turned off and can be identified by the symbol on the home screen:

Linearization can be recognized by the following symbol on the home screen 

1. Select **No Lin.** and confirm this with the button.
2. The **Save** icon will be displayed to indicate that the setting is saved.

The following pages describe the setting for each type of linearization.

LINEARIZATION HORIZONTAL TANK (WITH FLAT END)

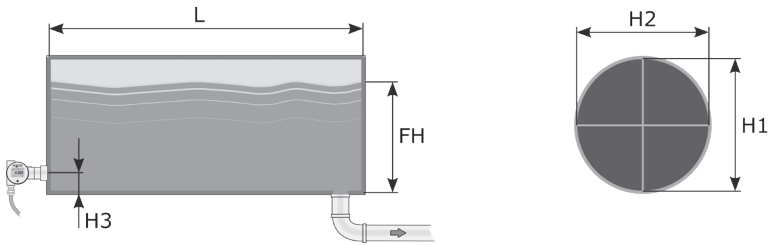

1. Navigate to **Hor. Tank.** with the navigation button, and press to confirm.
2. Two choices appear on the screen: **Input** and **Simulate**
3. Select **Input**, and press to confirm.
4. Six choices appear on the screen:

Display	Drawing	Explanation
Length	L	The length of the tank
Height 1	H1	The height of the tank
Height 2	H2	The diameter of the tank (with a cylindrical tank, this is equal to the height of the tank)
Height 3	H3	The height until the topside of the diaphragm (or weld-on nipple)
Height 4	H4	Value must be 0
Fill Height	FH	The maximum percentage of filling of the tank

5. Fill in each value except Height 4, and confirm each selection with the control button. The values must be entered in meters.
6. Select **SAVE** to save the setting.
7. The transmitter will return to the main menu

Simulation

After linearization is entered and stored, it is possible to perform a simulation based on the entered values. Based on the value entered in mWc, the transmitter will display the number of hectoliters (on the basis of the specified linearization values).

1. Navigate to program point **P111 – TANK LIN**, and press the navigation button to enter the menu.
2. Navigate to **Hor. Tank**. with the navigation button, and press to confirm.
3. Two choices appear on the screen: **Input** and **Simulate**
4. Select **Simulate**, and press to confirm.
5. Fill in the desired value based on mWc, the number of hectoliters change directly with a change in the value mWc.

LINEARIZATION HORIZONTAL TANK WITH A PARABOLIC END (CYLINDRICAL OR ELLIPTIC)

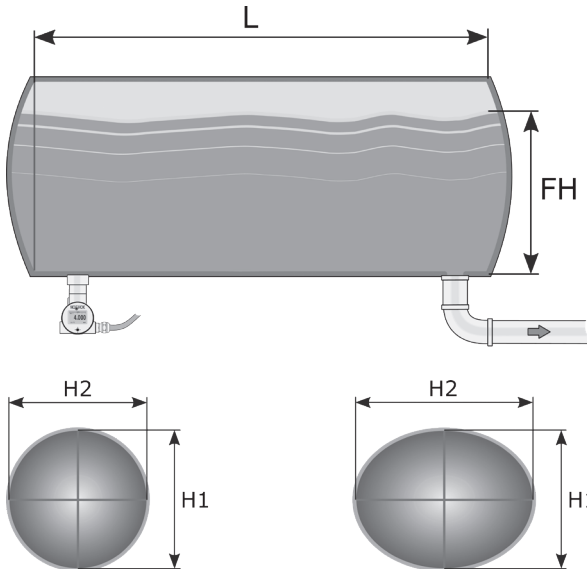

1. Navigate to **Hor. Tank.** button, and press to confirm.
2. Two choices appear on the screen: **Input** and **Simulate**
3. Select **Input**, and press to confirm.
4. Six choices appear on the screen:

Display	Drawing	Explanation
Length	L	The length of the tank
Height 1	H1	The height of the tank
Height 2	H2	The diameter of the tank (with a cylindrical tank, this is equal to the height of the tank)
Height 3	H3	The height till the topline of the diaphragm (or weld-on nipple)
Height 4	H4	The length of 1 parabolic end of the cylinder
Fill Height	FH	The maximum percentage of filling of the tank

5. Fill in each value, and confirm with the navigation button. The entered value's must be in meters.
6. Select **SAVE** to save the setting.
7. The transmitter will return to the main menu.

Simulation

After linearization is entered and stored, it is possible to perform a simulation based on the entered values. Based on the value entered in mWc, the transmitter will display the number of hectoliters (on the basis of the specified linearization values).

1. Navigate to program point **P111 – TANK LIN**, and press the navigation button to enter the menu.
2. Navigate to **Hor. Tank.** with the navigation button, and press to confirm.
3. Two choices appear on the screen: **Input** and **Simulate**
4. Select **Simulate**, and press to confirm.
5. Fill in the desired value based on mWc, the number of hectoliters change directly with a change in the value mWc.

LINEARIZATION VERTICAL TANK WITH A CONICAL BOTTOM

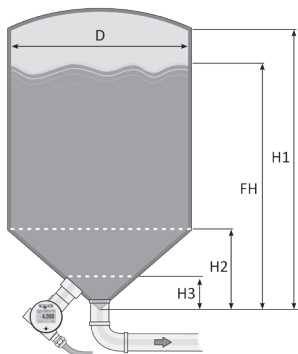

1. Navigate to **Vert. Cone.** with the navigation button, and press to confirm.
2. Two choices appear on the screen: **Input** and **Simulate**
3. Select **Input**, and press to confirm.
4. Six choices appear on the screen:

Display	Drawing	Explanation
Height 1	H1	The height of the tank
Diameter	D	The diameter of the tank
Height 2	H2	The height of the cone
Height 3	H3	The height till the topside of the diaphragm
Height 4	H4	The height of the parabolic tank roof
Fill Height	FH	The maximum percentage of filling of the tank

5. Fill in each value, and press to confirm.
The entered value's must be in meters.
6. Select **SAVE** to save the setting.
7. The transmitter will return to the main menu.

Simulation

After linearization is entered and stored, it is possible to perform a simulation based on the entered values. Based on the value entered in mWc, the transmitter will display the number of hectoliters (on the basis of the specified linearization values).

1. Navigate to program point **P111 – TANK LIN**, and press the navigation button to enter the menu.
2. Navigate to **Vert. Cone.** with the navigation button, and press to confirm.
3. Two choices appear on the screen: **Input** and **Simulate**
4. Select **Simulate**, and press to confirm.
5. Fill in the desired value based on mWc, the number of hectoliters changes directly.

LINEARIZATION VERTICAL TANK WITH A SPHERICAL BOTTOM

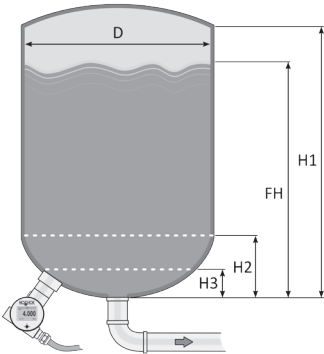

1. Navigate to **Vert. Sphere.** with the navigation button, and press to confirm.
2. Two choices appear on the screen: **Input** and **Simulate**
3. Select **Input**, and press to confirm.
4. Six choices appear on the screen:

Display	Drawing	Explanation
Height 1	H1	The height of the tank
Diameter	D	The diameter of the tank
Height 2	H2	The height of the spherical bottom
Height 3	H3	The height until the topside of the diaphragm
Height 4	H4	The height of the parabolic tank roof
Fill Height	FH	The maximum percentage of filling of the tank

5. Fill in each value, and press to confirm.
The entered value's must be in meters.
6. Select **SAVE** to save the setting.
7. The transmitter will return to the main menu.

Simulation

After linearization is entered and stored, it is possible to perform a simulation based on the entered values. Based on the value entered in mWc, the transmitter will display the number of hectoliters (on the basis of the specified linearization values).

1. Navigate to program point **P111 – TANK LIN**, and press the navigation button to enter the menu.
2. Navigate to **Vert. Sphere.** with the navigation button, and press to confirm.
3. Two choices appear on the screen: **Input** and **Simulate**
4. Select **Simulate**, and press to confirm.
5. Fill in the desired value based on mWc, the number of hectoliters change directly.

LINEARIZATION VERTICAL TANK WITH A TRUNCATED BOTTOM

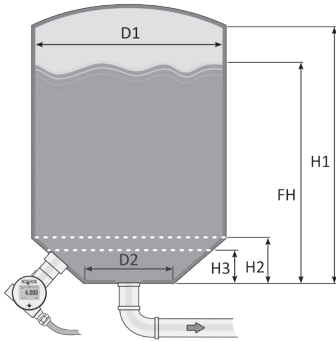

1. Navigate to **Vert. Trunc.** with the navigation button, and press to confirm.
2. Two choices appear on the screen: **Input** and **Simulate**
3. Select **Input**, and press to confirm.
4. Six choices appear on the screen:

Display	Drawing	Explanation
Height 1	H1	The height of the tank
Diameter 1	D1	The diameter of the tank
Height 2	H2	the height of the cone
Height 3	H3	The height till the topside of the diaphragm
Diameter 2	D2	The diameter of the truncated bottom
Fill Height	FH	The maximum percentage of filling of the tank

5. Fill in each value, and confirm with the navigation button. The entered value's must be in meters.
6. Select **SAVE** to save the setting.
7. The transmitter will return to the main menu.

Simulation

After linearization is entered and stored, it is possible to perform a simulation based on the entered values. Based on the value entered in mWc, the transmitter will display the number of hectoliters (on the basis of the specified linearization values).

1. Navigate to program point **P111 – TANK LIN**, and press the navigation button to enter the menu.
2. Navigate to **Vert. Trunc.** with the navigation button, and press to confirm.
3. Two choices appear on the screen: **Input** and **Simulate**
4. Select **Simulate**, and press to confirm.
5. Fill in the desired value based on mWc, the number of hectoliters change directly.

FREE LINEARIZATION

Free Linearization In Process:

1. Navigate to program point **P111 – TANK LIN**, and press to confirm.
2. Navigate to **Free lin.** with the navigation button, and press to confirm.
3. Two choices appear on the screen: **Measured** and **Manual**
4. Select **Measured** to configure a free linearization in a process situation.
5. Two choices appear on the screen: **Input** and **Simulate**
6. Select **Input**, and press to confirm
7. Five choices appear on the screen:

Clear table: The previous entered values for linearization will be deleted. It is advisable to use this feature for each time a new linearization is configured.



All entered values and dimensions of an existing/ previous linearization will be erased.

Volume units: Select the preferred unit: Liters, Hectoliters, Kg and Tons (after linearization the unit can be changed and selected in P109)

Height: The height of the tank can be filled in (highly recommended for an accurate linearization). The transmitter will determine with this height the span. A linearization will be made with the smallest possible deviation. Factory setting = Saved span in P102.

Start Point: The filling of a tank can be measured up to 70 points. The transmitter must be installed in an actual process to accomplish these measurements. The measuring must take place from low to high. (Filling an empty tank). The actual measuring will be displayed on the screen in percentage (%) for Xn (filling) and for Yn the measured volume. To enter the next measured point, move the navigation button up and enter the values.

Save: When all desired measurements are completed and all parameters have been set, the linearization must be saved. Press the navigate button to the left and select **SAVE** to save the linearization. The transmitter will return to the main menu.



WARNING AND PRECAUTIONS:

- When a tank filling (**Xn**) does not reach 100 % of the height of the tank, the transmitter will calculate the remaining part. This calculating method is linear and will only be used for the remaining part up to 100 %.



- It is not advisable to manually adjust the SPAN in program point P102 after a linearization has been configured. If the SPAN is adjusted after a linearization configuration, a warning will appear on the screen when entering P102.
- When a free linearization is used for measuring weight (Kg and Tons), a reliable accuracy cannot be guaranteed due to external influences such as heat and tank wall expansion.
The change of Specific Gravity due to different temperatures cannot be compensated by the PTI40 Series pressure transmitter.

Simulation

After linearization is entered and saved, it is possible to perform a simulation. (Based on the saved linearization) The transmitter will convert the entered mWc to hectoliters.

FREE LINEARIZATION MANUALLY

When it is not possible to enter and measure for a linearization in an actual process condition, a free linearization can be configured manually. Known measurements values and volumes must be entered manually in the transmitter.

1. Navigate to program point **P111 – TANK LIN**, and press the navigation button to enter the menu.
2. Navigate to **Free lin.** with the navigation button, and press to confirm.
3. Two choices appear on the screen: **Measured** and **Manual**
4. Select **Manual** to configure a free linearization manually.
5. Two choices appear on the screen: **Input** and **Simulate**
6. Select **Input**, and press to confirm.
7. Five choices appear on the screen:

Clear table: The previous entered values for linearization will be deleted. It is advisable to use this feature for each time a new linearization is configured.



All entered values and dimensions of an existing/ previous linearization will be erased.

Volume units: Select the preferred unit: Liters, Hectoliters, Kg and Tons (after linearization the unit can be changed and selected in P109)

Height: The height of the tank can be filled in (highly recommended for an accurate linearization). The transmitter will determine with this height the span. A linearization will be made with the smallest possible deviation. Factory setting = Saved span in P102.

Start Point: The contents of a tank can be configured up to 70 points. The entered value's must be from low to high (Filling an empty tank). The manually entered values will be displayed on the screen in percentage (%) for Xn and for Yn in Hectoliters. To enter the next measured point, move the navigation button up and enter the values.

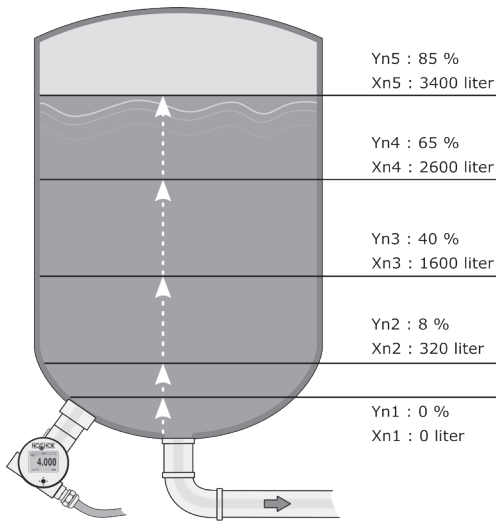

The figure shows a tank with standard dimensions. Free linearization can be applied on a wide variety of tanks with non-standard dimensions.

Example: A tank filling must be programmed in the transmitter.

- Choose **Clear Table** to remove all possible previous settings.
- Choose the preferred **Volume units**.
- Fill in the **Height** of the tank (highly recommended for an accurate linearization).
- In menu **Start Point** the linearization points can be filled in. In **Xn1** the percentage of the filling must be filled in. In **Yn1** the corresponding volume. After this, there are 69 more linearization points available.
- When all (needed) points are filled in, the linearization must be saved. Press the navigation button to the left and select **SAVE** to save this linearization.



WARNING AND PRECAUTIONS:

- When a tank filling (**Xn**) is not configured until 100 %, the transmitter will calculate the remaining part. This calculating method is linear and will only be used for the remaining part up to 100 %.



- It is not advisable to manually adjust the SPAN in program point P102 after a linearization has been configured. If the SPAN is adjusted after a linearization configuration, a warning will appear on the screen when entering P102.
- When a free linearization is used for measuring weight (Kg and Tons), a reliable accuracy cannot be guaranteed due to external influences such as heat and tank wall expansion.

The change of Specific Gravity due to different temperatures cannot be compensated by the PTI40 Series pressure transmitter.

Simulation

After linearization is entered and saved, it is possible to perform a simulation. (Based on the saved linearization) The transmitter will convert the entered mWc to hectoliters.

BURST MODE

The transmitter (Only when HART® is present) can be configured for Burst mode.

This will enable continuously broadcasting standard HART® reply messages.

1. Navigate to program point **P115 – Burst Mode** and press the navigation button to enter the menu.
2. A message appears on the screen, press to enter this menu.
3. Three choices appear on the screen: **0, 1** and **2**
4. With these choices, three distinct types of burst messages can be configured. Make a choice, and press the button to confirm.
5. Four choices appear on the screen: **Mode Cntrl, Cmd number, Period** and **Trigger** with these choices the chosen burst message (0,1 and 2) can be configured.
Select **Mode Cntrl**, and press to confirm.
6. Two choices appear on the screen: **On** and **Off**
 - Choose **On** to turn on burst mode.
 - Choose **Off** to turn off burst mode.
7. Select **Cmd number**, and press to confirm.
Five choices appear on the screen:
 - **Cmd 01** = PRIMARY VARIABLE
 - **Cmd 02** = CURRENT AND PERCENT OF RANGE
 - **Cmd 03** = DYNAMIC VARIABLES AND CURRENT
 - **Cmd 09** = DEVICE VARIABLES WITH STATUS
 - **Cmd 48** = ADDITIONAL TRANSMITTER STATUSChoose the preferable burst mode, and press to confirm.
8. Select **Period**, and press to confirm.
Two choices appear on the screen: **Max Time** and **Min Time**
 - Select **Max Time** to set the maximum amount of time when the message will be sent.
This value can be set from 0.5 to 3600 seconds.
 - Select **Min Time** to set the minimum amount of time when the message will be sent.
This value can be set from 0.5 to 3600 seconds.Enter the preferred value, and press to confirm.
9. Select **Trigger**, and press to confirm.

10. Five choices appear on the screen:
- **Continuous** = The Burst message is sent continuously.
 - **Windowed** = The Burst message is triggered when the measured value deviates more than the specified trigger value.
 - **Rising** = The Burst message is triggered when the measured value rises above the triggered value.
 - **Falling** = The Burst message is triggered when the measured value falls below the triggered value.
 - **On-Change** = The Burst message is triggered when any value in the measurement changes.
11. Choose the desired burst mode, and set the preferred parameters.

P113

INFORMATION

This menu shows a collection of information from the transmitter and contact information from the manufacturer.

1. Navigate to program point **P113 - Information** and press the navigation button to enter the menu.
2. Press the navigation button up and down to see all of the information
3. Press the button to leave this menu.

Below is a representation of this information screen:

Version	Software revision
No:	Serial number transmitter
Zero	Zero (Bar)
Span	Span (Bar)
Damping	Damping (in seconds)
Output	Output 4-20 or 20-4 mA
Local Prot	Protection On or Off
Alarm	Alarm output (3.2 or 22.8 mA)
Sec. Value	Selected secondary configuration
Backlight	Backlight On, Sleep mode or Off
Temp	Temperature unit Celsius or Fahrenheit
HART® version	HART® version 5 or 7 (when HART® is present)

P114**SQUARE ROOT**

In this menu the characteristics of a flow, volume and differential pressure measuring can be configured. The following options are available:

1. Navigate to program point **P114 – Square root**, and press the navigation button to enter the menu.
2. Five choices appear on the screen:
 - **Function**
 - **Linear:** The differential pressure measuring between 0 and 100 % of the span.
 - **Square root:** Flow and Volume measuring The Zero (Program point P101) will automatically be set to 0.000 when enabling the Square Root function. After enabling the Square Root function, the Zero (Program point P101) cannot be configured.
 - **Cut off:** The Square root function can be enabled with an adjustable cut off value between 0 and 20%. The cut off adjustment prevents high gain on low values from the Square Root extraction.

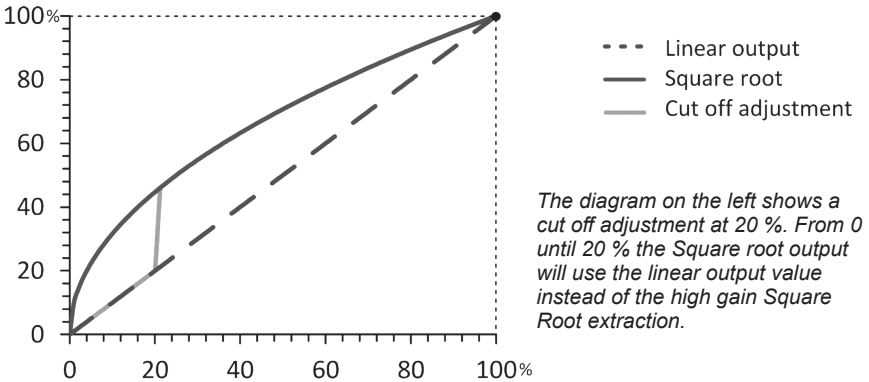

- **Square Root unit:** Multiple engineering units can be selected. Each selected unit is automatically converted to the correct value of the corresponding unit. The following units can be selected:

Volumetric Flow units

Unit	Description
ft ³ /m	Cubic feet per minute
gal/m	Gallons per minute
l/m	Liters per minute
iGal/m	Imperial gallons per minute
m ³ /h	Cubic meter per hour
gal/s	Gallons per second
Mgal/d	Million gallons per day
l/s	Liters per second
MI/d	Million liters per day
ft ³ /s	Cubic feet per second
ft ³ /d	Cubic feet per day
m ³ /s	Cubic meters per second
m ³ /d	Cubic meters per day
iGal/h	Imperial gallons per hour
iGal/d	Imperial gallons per day
m ³ /h	Normal cubic meter per hour (MKS System)
l/h	Normal liter per hour (MKS System)
ft ³ /m	Standard cubic feet per minute
ft ³ /h	Cubic feet per hour
m ³ /m	Cubic meters per minute
bbl/s	Barrels per second (1 barrel equals 42 U.S. gallons)
bbl/m	Barrels per minute (1 barrel equals 42 U.S. gallons)
bbl/h	Barrels per hour (1 barrel equals 42 U.S. gallons)
bbl/d	Barrels per day (1 barrel equals 42 U.S. gallons)
gal/h	Gallons per hour
iGal/s	Imperial gallons per second
l/h	Liters per hour
gal/d	Gallons per day

Mass Flow units

Unit	Description
g/s	Grams per second
g/m	Grams per minute
g/h	Grams per hour
kg/s	Kilograms per second
kg/m	Kilograms per minute
kg/h	Kilograms per hour
kg/d	Kilograms per day
T/m	Metric tons per minute
T/h	Metric tons per hour
T/d	Metric tons per day
lb/s	Pounds per second
lb/m	Pounds per minute
lb/h	Pounds per hour
lb/d	Pounds per day
sT/m	Short tons per minute
sT/h	Short tons per hour
sT/d	Short tons per day
IT/h	Long tons per hour
IT/d	Long tons per day

To display the Square Root output on the display, navigate to program point **P109 - READOUT**, and press to confirm. Navigate to **Square Root** and press to confirm.

The readout on the display will now show the Square Root output, and displayed by the symbol  on the home screen.

The scale of the readout can be adjusted between ≥ 0 and 100 by adjusting the scaling in the Lower and Upper range values

- **Unit LRV:** The Lower Range Value can be adjusted between ≥ 0 and 100. Press the navigation button to enter the menu. A value can be entered. Press to confirm. The **Save** icon will be displayed to indicate that the setting is saved
- **Unit URV:** The Upper Range Value must be at least ≥ 10 higher than the Lower Range value and

can be adjusted up to 100. Press the navigation button to enter the menu. A value can be entered. Press to confirm. The **Save** icon will be displayed to indicate that the setting is saved.

P115

FACTORY

Only available for the manufacturer.

P116

FACTORY

Only available for the manufacturer.

7 PROGRAMMING THE PTI40 SERIES

7.1 PROGRAMMING WITH HAND HELD TERMINAL



When using HART® or a Hand Held Terminal (HHT), a minimum resistance of 250 Ω must be present in the loop of the 2-wire system. This is necessary for proper communication (see drawing below). A power supply of at least 17 Vdc must be used.

The Series PTI40 can be easily programmed with the Hand Held Terminal (HHT) from the HART® Foundation (Type 275 or 375 HART® Communicator).

Option 1: HART® Handheld terminal connected across the transmitter.

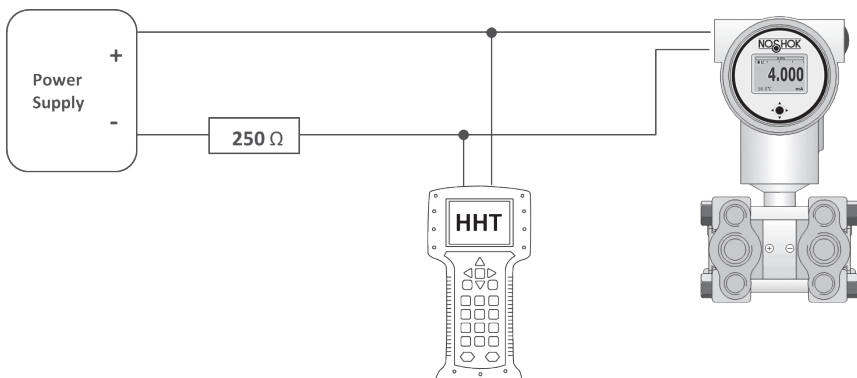

Option 2: HART® Handheld terminal connected across the loop resistor.

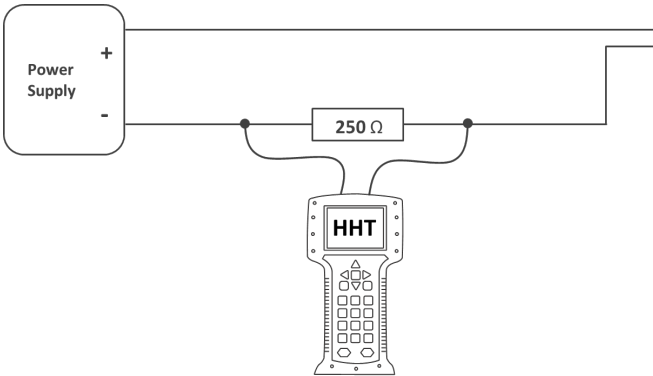

7.2 ROTATABLE DISPLAY

The display from PTI40 Series is fully rotatable. To rotate the display, place a small screw driver into the recess on top of the display. Turn it by hand by moving the screw driver into the desired direction, use the other hand to guide this movement to avoid any damages. The display can be turned both left and right.



8 SPECIFICATIONS

Manufacturer	NOSHOK		
Instrument	Series PTI40		
Output	4-20 mA HART® Protocol		
Power Supply	Standard : 12 – 36 Vdc HART® : 17 – 36 Vdc (Standard) min. 250 Ω		
Accuracy¹	Turn Down 10:1 - 0.075 % Turn Down 20:1 - 0.1 % Turn Down 40:1 - 0.15 % Turn Down > 40:1 – 0.005 % x TD		
Ranges	Adjustable span ranges		Max. overpressure
	Min. Span	Max. Span	
Series PTI40	0 - 0.15 psi	0 - 1 psi	2321 psi
	0 - 0.15 psi	0 - 6 psi	
	0 - 0.3 psi	0 - 30 psi	
	0 - 3 psi	0 - 300 psi	
Process Temperature²			
	Standard	-4°F to 158°F	
Ambient Temperature			
	Standard	-4°F to 158°F	
Damping	0.00 seconds to 25.00 seconds Standard: 0.00 seconds.		
Protection Grade	IP66		
Material			
	Housing Wetted parts	304 SS (Optional 316 SS) 316 L SS and Viton O-Ring (Other materials on request)	

¹ To achieve the highest accuracy, always choose the instrument range closest to the required Calibrated span.

Example: Required Calibrated range 0 - 4.35 psi

² For higher temperatures use other kind of pressure transmitters, contact NOSHOK for information.

9 PRECAUTIONS AND WARNINGS

- Check if the specifications of the transmitter meet the needs of the process conditions
- When the Series PTI40 is used as a level transmitter, be aware of the place where the transmitter is mounted. Here are some suggestions:
 1. Do not mount a level transmitter in- or near filling or discharging pipes.
 2. In case of automatic cleaning systems or hand cleaning: never point the water jets on the diaphragm, take necessary steps to avoid this.
- When the Series PTI40 is used as a pressure transmitter, be aware of the following points:
 1. Rapid closing valves in combination with high flow velocity will cause water hammer(spikes) and can destroy the transmitter. Do not mount a transmitter near such valves, always a few pipe bends away up or down stream (avoid suction).
 2. Install a pressure transmitter a few pipe bends away from pumps, as well on the suction or pressure side of the pump
- The diaphragm of the transmitter is protected with a special protection cap. Protect the diaphragm until installation takes place, to prevent damaging of the diaphragm.
- As soon as the wiring is brought inside through the cable gland and connected to the terminal board, make sure the cable gland is tightly fixed, so that moisture cannot enter into the electronic housing.
- The covers (1) and (3) must be fully engaged, so that moisture cannot ingress into the electronic housing.
- The warranty is 3 years from delivery date. NOSHOK does not accept liability for consequential damage of any kind due to use or misuse of the Series PTI40.
- NOSHOK reserves the right to change its specifications at any time, without notice. NOSHOK is not an expert in the customer's process (technical field) and therefore does not warrant the suitability of its product for the application selected by the customer.



Corporate Headquarters

1010 West Bagley Road
Berea, Ohio 44017

Ph: 440.243.0888

Fax: 440.243.3472

E-mail: noshok@noshok.com

Web: www.noshok.com

ISO 9001:2015

REGISTERED

NK23PTI40UM